

SAVAR 2100

THE NEW GENERATION OF WEIGHING HAND PALLET TRUCKS



HIGH ACCURACY: MAXIMUM ERROR 0.1% OF APPLIED WEIGHT, INDEPENDENT OF FLOOR CONDITION AND POSITION OF THE LOAD

DEVELOPED FOR INDUSTRIAL APPLICATIONS: RESISTANT TO SHOCKS AND VIBRATION

USER-FRIENDLY DIGITAL INDICATOR; OPTION RS 232 DATA OUTPUT (DATA COMMUNICATION; PRINTER)

WATERPROOF: TO IP 65 PROTECTION CLASS

ERGONOMIC DESIGN: LEVER FUNCTIONS WHICH CAN BE OPERATED RIGHT OR LEFT-HANDED; LOW OWN WEIGHT

EASILY EXCHANGEABLE BATTERY PACK FOR CONTINUOUS USE; DELIVERED INCLUDING CHARGING MODULE

LOW POWER CONSUMPTION; AUTOMATIC SWITCH-OFF

FUNCTIONALITY

- ◆ Automatic and manual zero correction
- ◆ Gross/net weighing
- ◆ Automatic and manual tare
- ◆ Totalisation with sequence number
- ◆ Error messages in display
- ◆ Automatic switch-off after 60 minutes of non-use (programmable)



Exchangeable battery module

RAVAS

DIMENSIONS

A	Fork length	: 1150 mm
B	Fork width	: 170 mm
C	Minimum fork height	: 85 mm
	Minimum space between floor and forks	: 22 mm
D	Maximum fork height	: 205 mm
	Lifting height	: 120 mm
E	Width over forks	: 540 mm
F	Height to top indicator	: 770 mm

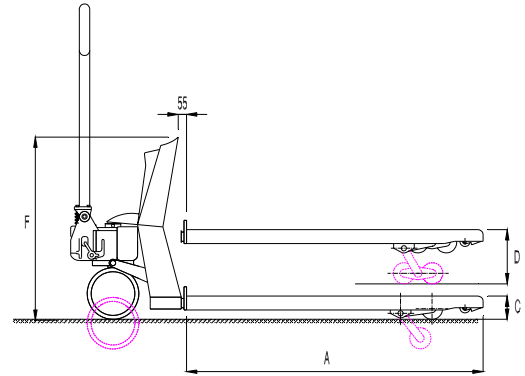

PRECISION STANDARD VERSION

Max. inaccuracy : 0.1% of the applied weight

Graduation	: multi-range
	0 - 200 kg: graduation 0.2 kg
	200 - 500 kg: graduation 0.5 kg
	500 - 2200 kg: graduation 1 kg

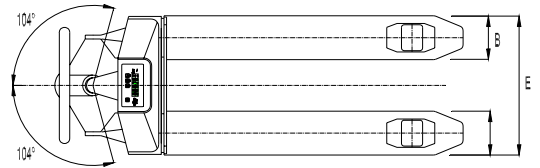

PRECISION APPROVED FOR TRADE VERSION CLASS III

Multi-range or options possible:

- 1000 divisions:	1.0 / 1000 kg or 2.0 / 2000 kg
- 1500 divisions:	0.5 / 750 kg or 1.0 / 1500 kg
- 2000 divisions:	0.5 / 1000 kg or 1.0 / 2000 kg
- 3000 divisions:	0.1 / 300 kg or 0.2 / 600 kg or 0.5 / 1500 kg

STANDARD SPECIFICATIONS

Weighing capacity	: 2200 kg
Display	: LCD, height 18 mm
Keypad	: 3 function keys, on / off key
Protection class	: load cells and cabling IP 67, indicator IP 65
Steering wheels	: rubber
Loading wheels	: poly-urethane, single
Colour	: red (RAL 3000), epoxy painted
Own weight	: 99 kg
Battery	: 12 Vdc / 1.2 Ah, interchangeable; delivery including separate charging module
Battery life	: 35 hours low voltage indication 5 hours before automatic switch-off; automatic switch-off after 60 minutes of non-use (programmable)
Charger	: 230 Volt / 12 Vdc - 300 mA
Duration of charge	: approx. 6 hours
Class III	: European approval no. T2782 switch-off of display when tilting more than 2°

OPTIONS WEIGHING SYSTEM *

Approved version	: legal for trade class III
Graduation	: finer multi-range 0.1 / 0.2 / 0.5 kg (with reduced weighing capacity)
RS 232 output	: for data communication (e.g. with printer)
Built-in printer	: for printing weighing data on- site
LED display	: not in combination with RS 232 (printer) or approved version
Push buttons	: for easy operation when wearing gloves
Rotating indicator	: for reading display from all angles
Theft protection	: user identification by card
2nd battery module	: for continuous use
Explosion-proof version	: EEx II B T4

OPTIONS HAND PALLET TRUCK *

- Stainless steel version
- Stainless steel forks
- Galvanised version
- Height adaptor frame
- Steering wheels in vulcolan or nylon
- Loading wheels in nylon and / or tandem
- Hand-brake
- Footbrake (steel or stainless steel)
- Quick lift
- Capacity 3000 kg (graduation 1 kg)
- Fork length from 950 mm to 2000 mm
- Width over forks 690 mm

* For special options the dimensions can differ from the above standard specifications

RAVAS

RAVAS Europe B.V.

Postbus 2023
5300 CA Zaltbommel
THE NETHERLANDS
☎ +31 - 418 - 51 52 20
📠 +31 - 418 - 51 53 20
www.ravas.com
Ref.: saVar2100/NL/000823/v1