

## Technical Specification

Accuracy	C3
Rated output	2.0 mV/V $\pm$ 0.1%
Rated capacities	300, 500, 1,000, 2,000, 3,000, 5,000 kg
Combined error	$<\pm$ 0.017%*
Non-repeatability	$<\pm$ 0.015%*
Creep (30 minutes)	$<\pm$ 0.016%*
Temperature effect on zero balance	$<\pm$ 0.01%*/°C
Temperature effect on span	$<\pm$ 0.006%*/°C
Compensated temperature range	-10 to +40°C

Operating temperature range	-20 to +70°C
Safe overload	150%*
Ultimate overload	200%*
Zero balance	$<\pm$ 2%*
Input impedance	1,150 ohms $\pm$ 60
Output impedance	1,000 ohms
Insulation resistance	$>$ 5,000 megaohms @ 100 V
Recommended supply voltage	5 ... 10 V
Maximum supply voltage	15 V
Environmental protection	IP68
Cable	10m signal cable
ATEX Certification	II I GD T85°C EEx ia IIC T6

\*with respect to rated output

## Dimensions

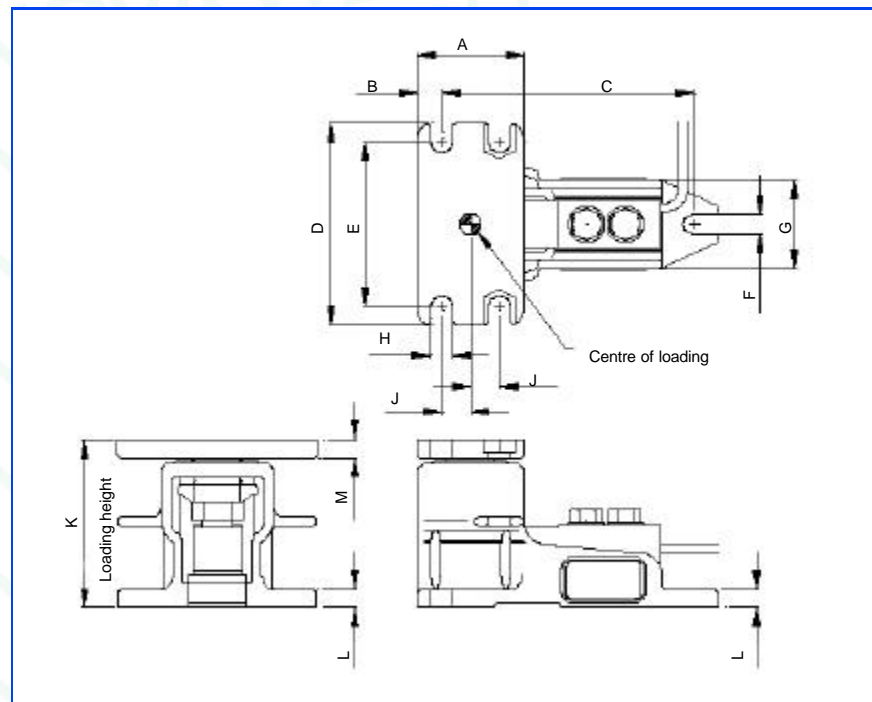

### Electrical Connections

Via 6 core, 7/0.2 mm (0.22 mm<sup>2</sup>), screened pvc cable

In all cases screen is not connected electrically to the load cell

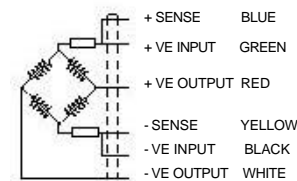

Capacity (kg)	A	B	C	D	E	F	G	H	J	K	L	M
300, 500, 1000, 2000	70	16	168	132	108	14	60	14	19	110	12	12
3000, 5000	100	25	225	190	150	22	80	22	25	157	15	20



# NOVA WEIGH



BS EN ISO 9001:2000 Cert No: FM 11445

Nova Weigh's policy of constant product development dictates that we may alter specifications and or the appearance of our product range without notice.

LeverMount/06/06

## LeverMount®

# NOVA WEIGH

Capacities: 300 kg 2,000 kg  
500 kg 3,000 kg  
1,000 kg 5,000 kg

- Purpose designed stainless load cell and mount arrangement
- Load cell removal without jacking or dummies
- Highly stable three point mounting
- Easily configurable for radial or tangential mounting
- Allows for vessel expansion and contraction
- LeverMount® can be raised and lowered under load without jacking
- Straightforward, low cost installation without specialist tooling
- Substantial lift off prevention
- Tolerant of steel work misalignment
- ATEX certified II I GD T85°C EEx ia IIC T6 - suitable for Gas and Dust hazards
- Stainless steel OIML C3 approved load cell, fully welded, sealed to IP68

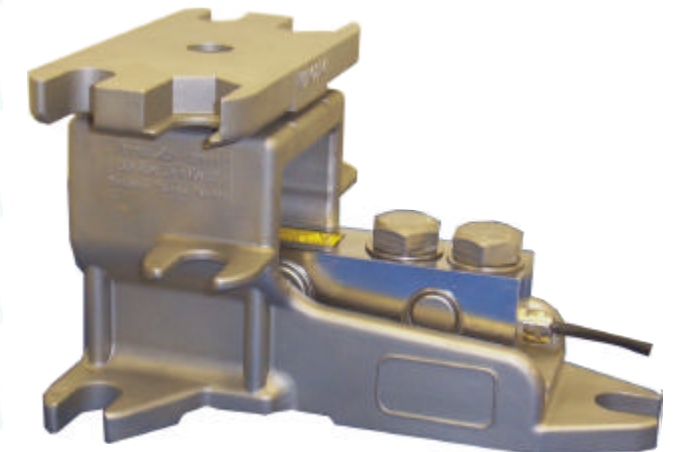

A Unique, Patented and Cost Effective Solution for Process Weighing Applications

# NOVA WEIGH

## LeverMount®

The concept of a purpose designed loading assembly using single ended shear beam load cells for vessel weighing was first introduced in the early 1980's.

LeverMount® is the next generation of load cell weighing assemblies, purpose designed to offer a completely fresh approach to process weighing solutions.

LeverMount® retains the advantage of existing mounts, whilst providing improved mechanical stability before and during installation. LeverMount® can be raised or lowered under load without specialised tools; additionally, the load cell can be removed or replaced without the need for jacking or dummies.

## Uniqueness & Simplicity

Many existing mounting assemblies provide a jacking feature which allows a vessel to be supported by the mounts prior to the installation of the load cells. Typically, the mounts will initially be fitted in a fully jacked condition; this avoids the risk of damage to the load cell, either as a result of physical abuse, or a consequence of arc welding or other mechanical activity.

Once the vessel is secured in position, the load cell is installed, and the top plate of the mount is then jacked down onto the load button, making the system live.

The tried and tested method of jacking a mount is by means of one or more threaded support pillars which engage with the top plate of the mount. This arrangement works to best advantage when the load applied to the mount is small - often when the vessel is empty. Under other load conditions, an external jack is usually employed to raise and lower the vessel in order to avoid overloading the support pillars.

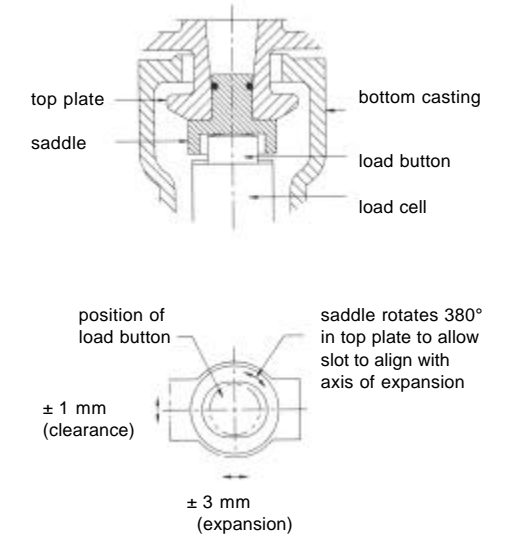
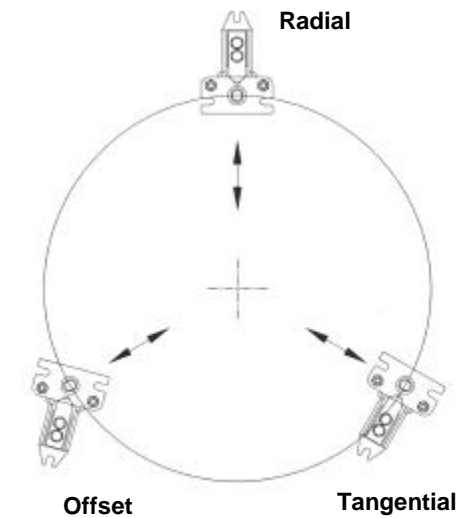
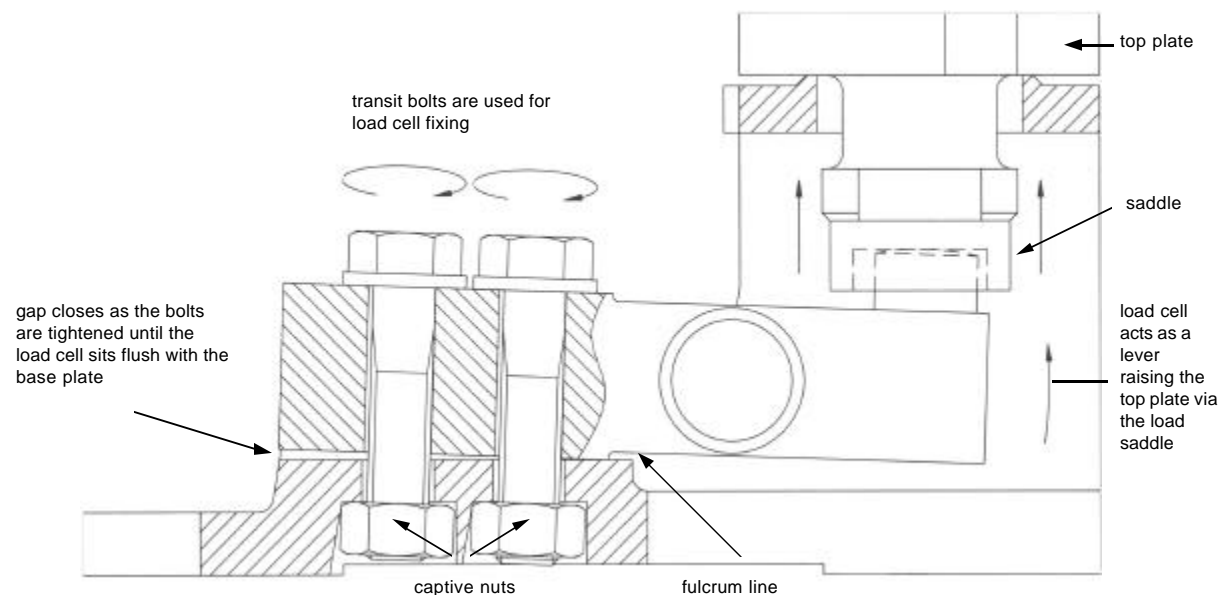

## Features

- Purpose designed stainless steel cast mount and stainless steel load cell
- Simple two part casting using the transit bolts into captivated nuts for load cell fixing
- Stainless steel, IP68, fully welded, single ended shear beam load cell
- Load cell acts as the lever to raise and lower the top plate and vessel
- Vessel can be raised or lowered under load
- No jacking screws or support pillars
- Three point support and fixing
- Top plate movement in the x, y and rotational axis
- Configurable for radial, tangential or offset mounting
- Substantial anti-lift facility
- Nominal difference between the working height and the installed height
- Load cell can be easily removed under load in situ
- Two designs cover the range from 300 kg to 5000 kg

## Benefits

- Ideal for process weighing applications that require an accurate, safe and cost effective solution
- Aesthetically pleasing design, eliminating the need for additional machining and special bolts
- Suitable for use within the harshest of industrial environments
- No need for alternative lifting devices such as pad jacks
- Easier, quicker and safer than any other mount arrangement
- No stripped threads or top plate interference
- Eliminates rocking and twisting in the mount, always finds a plane
- Tolerant of steel work misalignment; allows the vessel to breath avoiding any mechanically induced errors
- Easy alignment to the radial axis of the vessel
- Increased safety
- Reduces the need to adjust for pipework without flexible connections
- Less down time
- Covers the majority of process weighing applications

